

PUBLIC ADDRESS / SPEAKERS / CEILING

## GAT-80SW

100 V LINE TRANSFORMER CEILING SUBWOOFER SPEAKER



- ✓ Excellent sound quality
- ✓ Anchorage installation system

ESPECIALLY RECOMMENDED IN:



Hospitality



Retail



Hotels



All sectors

### DESCRIPTION

Subwoofer ceiling speaker Perfect for bass reinforcement in installations with musical ambience. It delivers great

power with deep bass. ABS built and protective steel grille that guarantees its integrity. Its simple anchor installation system minimises assembly time, with the screws being completely hidden behind the grille. Bass reinforcement for musical ambience of 100 V line installations in shops, bars, restaurants, etc.

**TECHNICAL CHARACTERISTICS**

FEATURES	Ceiling subwoofer, with 100 V line transformer and round grille. Bass reinforcement in 100 V line installations.
POWER	90 W maximum, 60 W RMS
LOUDSPEAKERS	1 X 8" woofer
RESPONSE	55-200 Hz -10 dB at 1W/1m
IMPEDANCE	60 W RMS@100V (166 Ohm) 40 W RMS@100V (250 Ohm) 20 W RMS@100V (500 Ohm)
SENSITIVITY	89 dB at 1 W/1 m
CROSSOVER	Low-pass filter, 12 dB/oct.
MATERIAL	ABS and steel grille
COLOUR	Greyish white (RAL 9003, RAL 7047)
DIMENSIONS	275 mm Ø x 110 mm depth
HOLE	240 mm Ø
WEIGHT	2.5 kg
	Installation system with catches

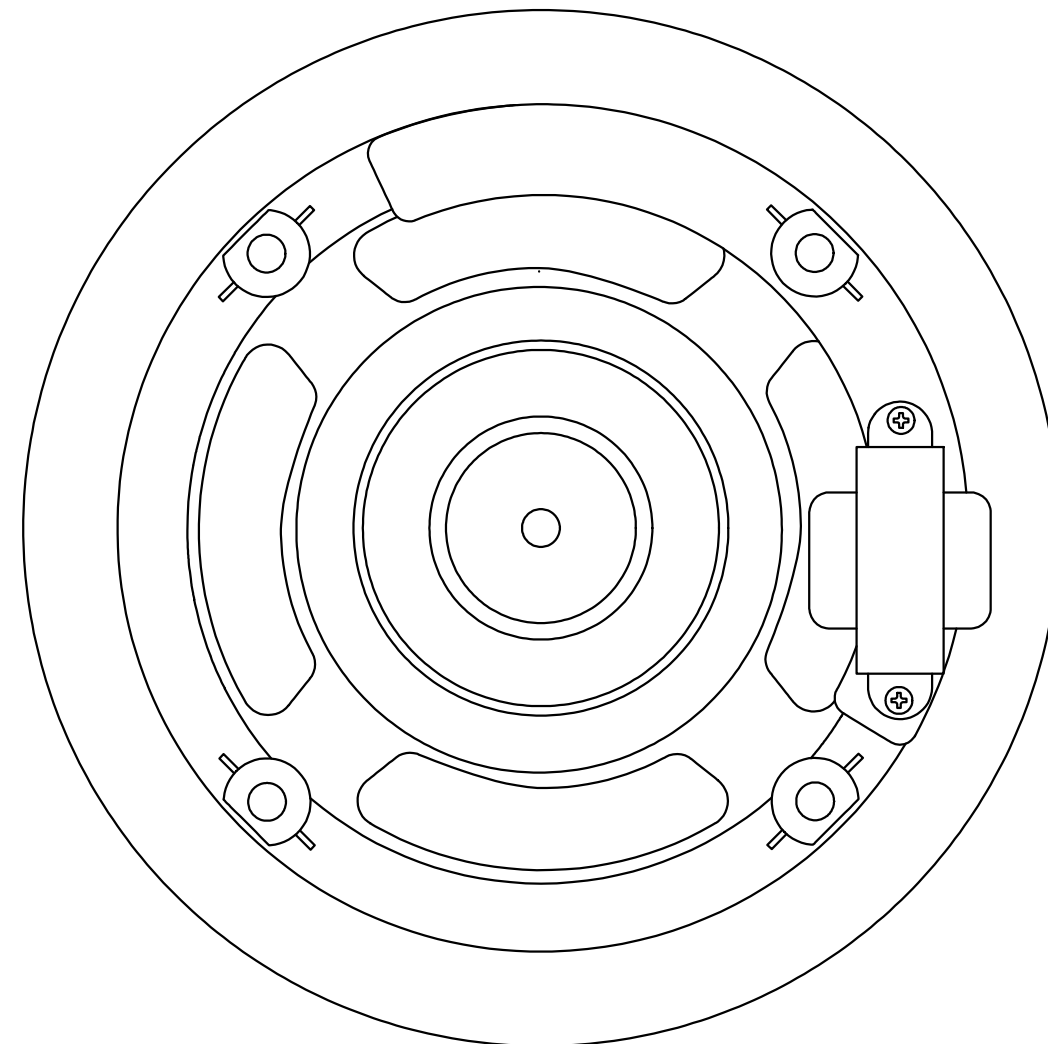
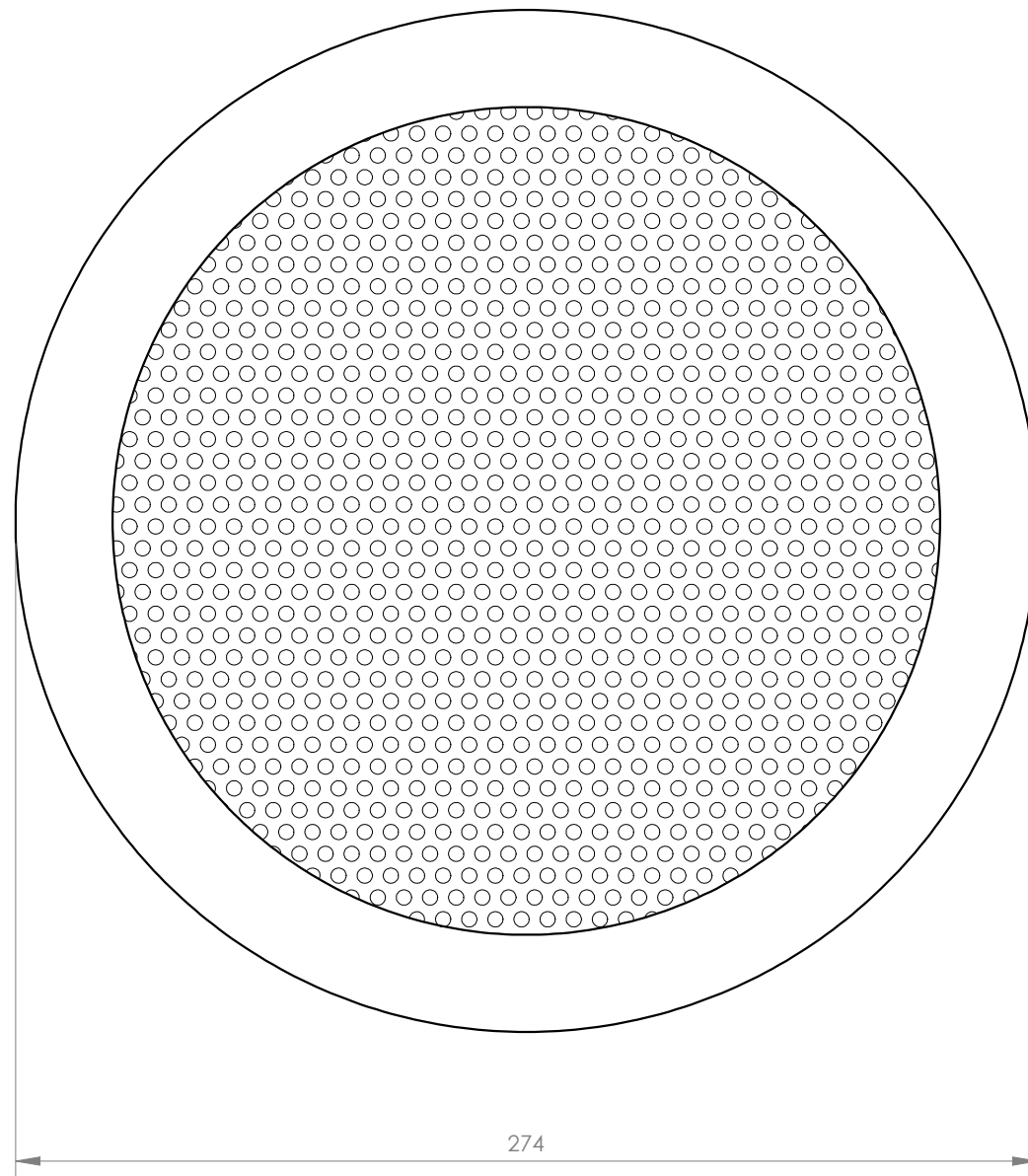
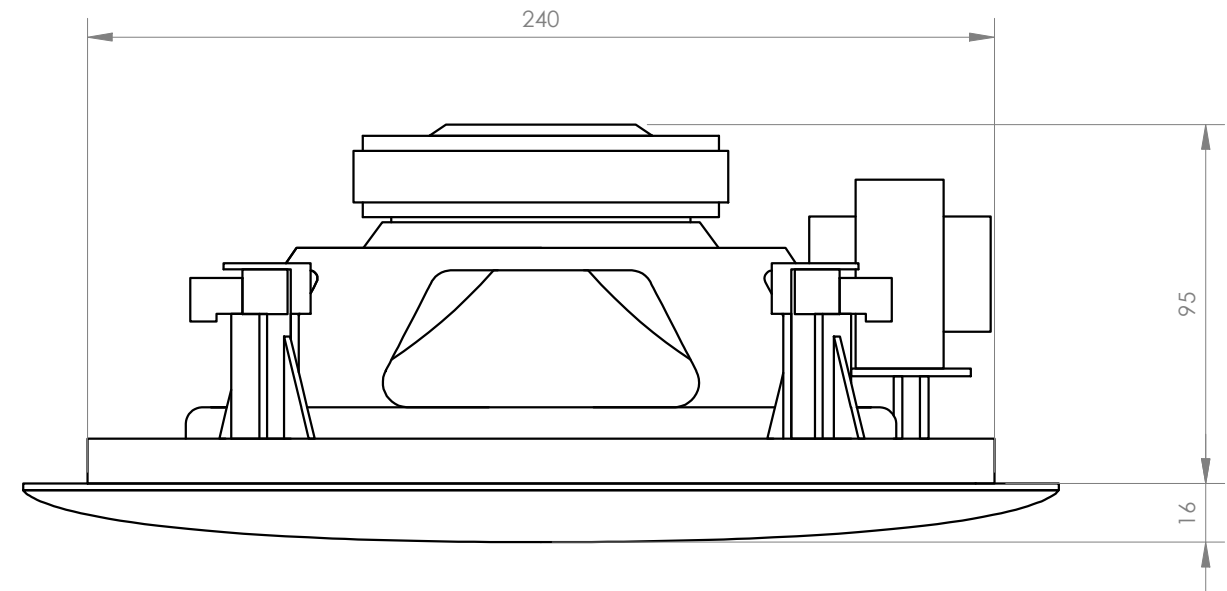

FONESTAR	Model	Description	Units	Scale
	GAT-80SW	100 V LINE TRANSFORMER CEILING SUBWOOFER SPEAKER	mm	1:2