

PUBLIC ADDRESS / SPEAKERS / CEILING

# GAT-501

CEILING LOUDSPEAKER WITH 100 V LINE TRANSFORMER

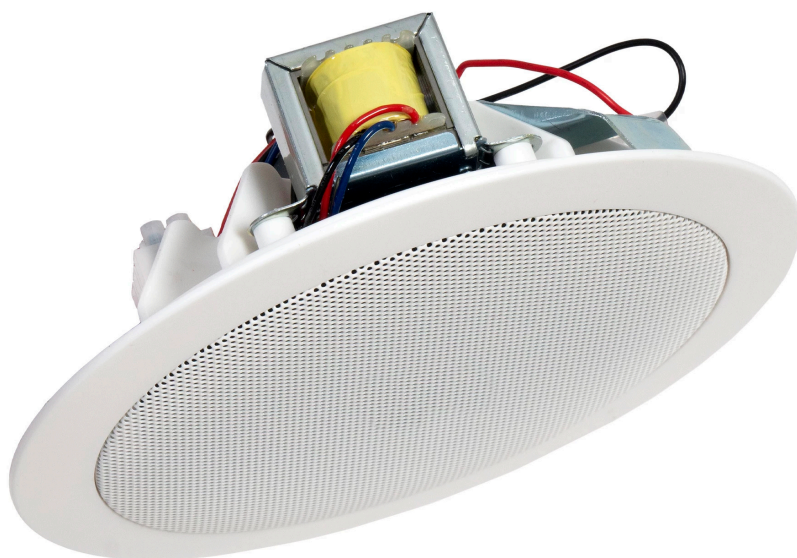

- ✓ Crisp and clean sound
- ✓ ABS built with fireproof case and steel grille
- ✓ Quick installation system

ESPECIALLY RECOMMENDED IN:



Hospitality



Retail



Hotels



All sectors

**DESCRIPTION**

Ceiling loudspeaker for sound reinforcement. It offers a clear and crisp sound, perfect for voice and background music. Built in ABS and steel grille that guarantees its integrity. It has a quick installation system that minimises assembly time. For background music and voice announcements in 100 V line installations in offices, shops, restaurants, waiting rooms, etc.

**TECHNICAL CHARACTERISTICS**

FEATURES	Ceiling loudspeaker with 100 V line transformer and round grille.
POWER	10 W maximum, 6 W RMS
LOUDSPEAKERS	5" double cone
RESPONSE	140-15,000 Hz
IMPEDANCE	6 W RMS@100V (1,660 Ohm) 3 W RMS@100V (3,330 Ohm)
SENSITIVITY	90 dB ±3 dB at 1 W/1 m
MATERIAL	ABS and steel grille
COLOUR	White (RAL 9003)
DIMENSIONS	175 mm Ø x 60 mm depth
HOLE	150 mm Ø
WEIGHT	0.5 kg
	Quick installation system

**SPL vs Frequency**

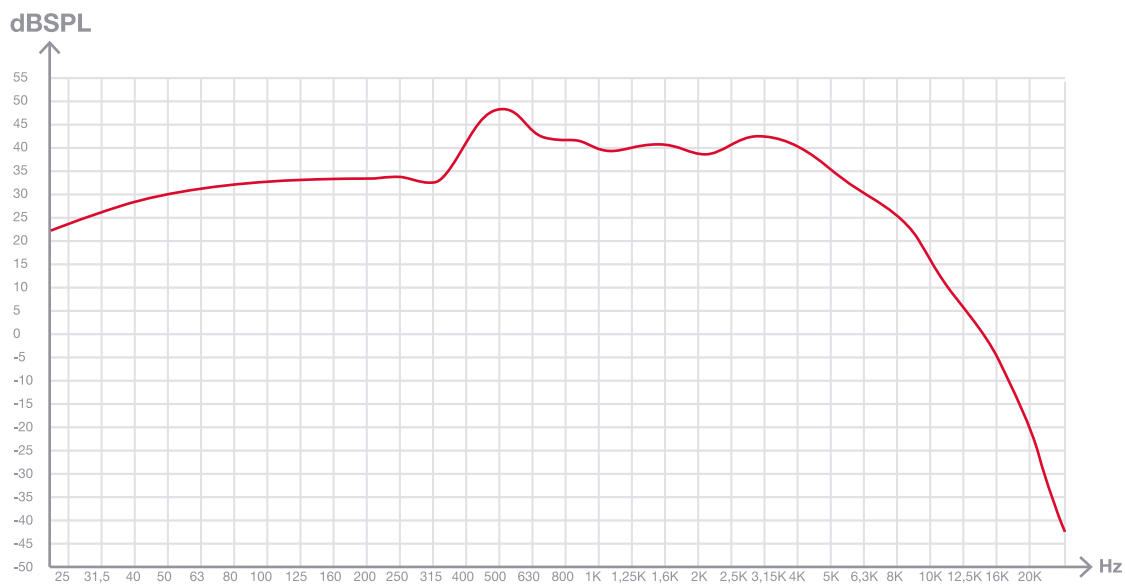

**SPL vs Angle**

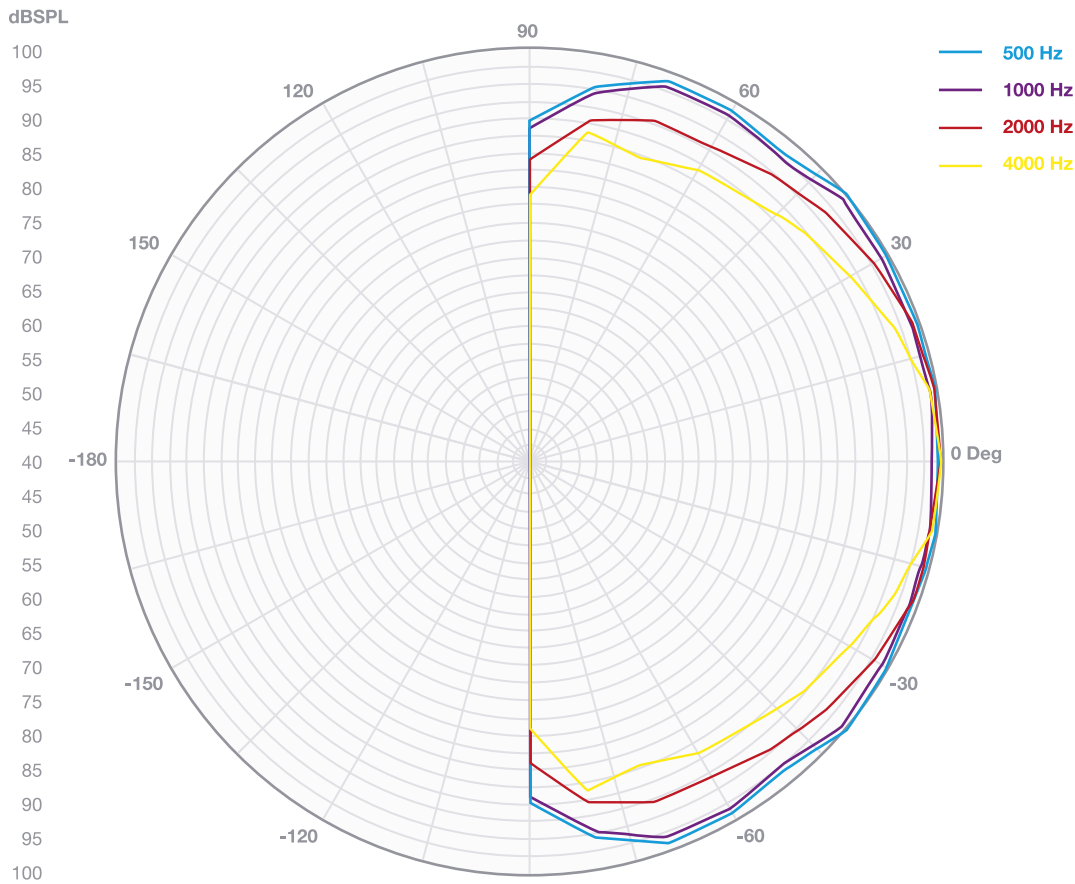

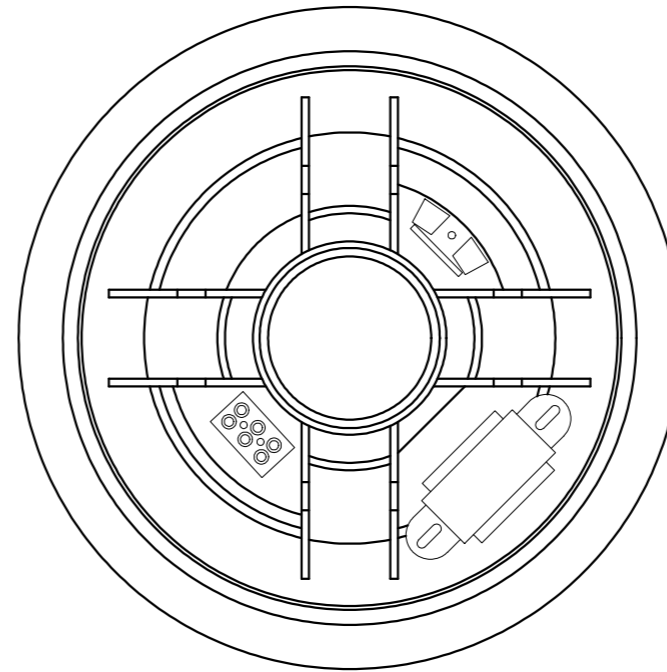
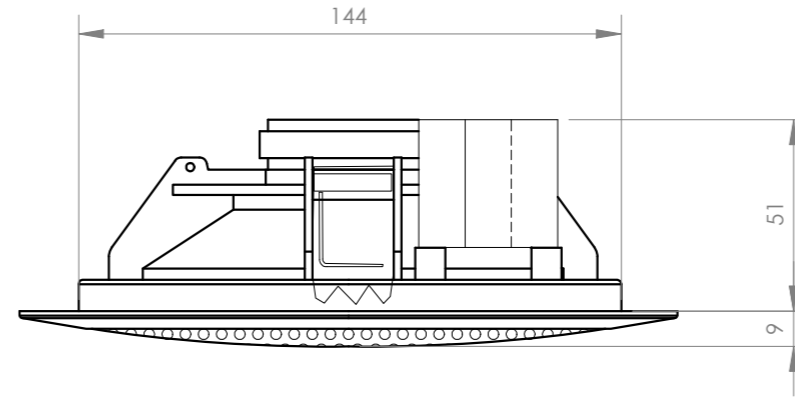
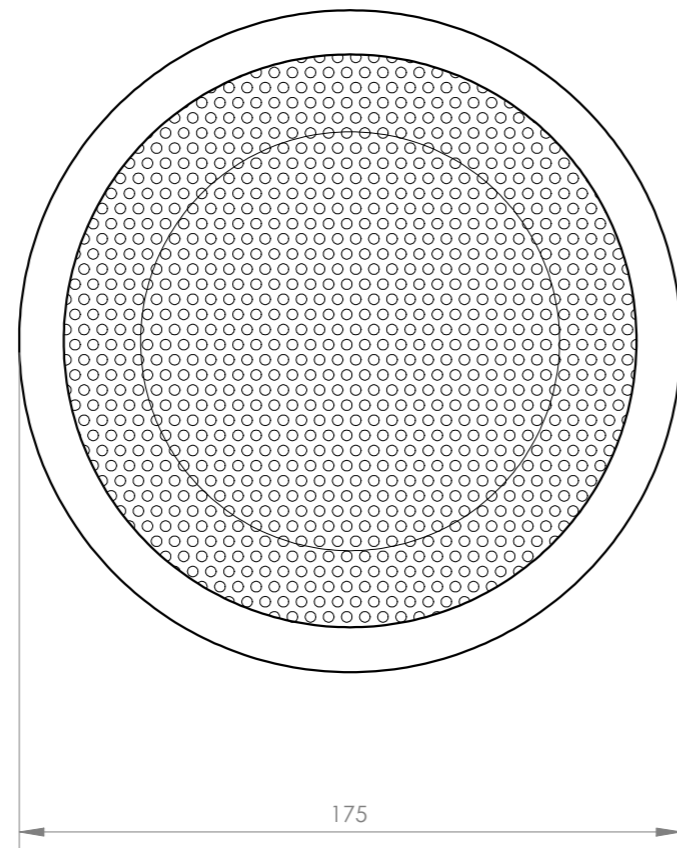

**FONESTAR**

Model  
GAT-501

Description  
100 V LINE TRANSFORMER CEILING SPEAKER

Units  
mm

Scale  
1:2