

PUBLIC ADDRESS / AMPLIFIERS / MONO

PROX-15

PA SINGLE ZONE AMPLIFIER



- ✓ Excellent sound quality
- ✓ Modern and discreet design
- ✓ USB/FM player
- ✓ Compact size, for desktop use
- ✓ Secure, easy-to-connect euroblock connectors

ESPECIALLY RECOMMENDED IN:



Factories



Sports facilities



Education



All sectors

DESCRIPTION

Public address amplifier with USB/FM player. A perfect solution integrating amplifier, mixer, player, microphone and auxiliary inputs in a single unit, for PA installations with 100 V or low impedance loudspeakers requiring intuitive operation on a tight budget. Secure, easy-to-connect euroblock connectors. Excellent sound quality. Modern and discreet design. Compact size, for desktop use or surface anchorage. For public address and piped music systems with 100 V or low impedance line loudspeakers. Commercial premises, educational centres, public address vehicles, monuments, exhibitions, bars, restaurants, etc.

TECHNICAL CHARACTERISTICS

FEATURES	<p>Public address amplifier.</p> <p>USB/FM player.</p> <p>Microphone input with mix, gain and priority level control.</p> <p>Tone controls.</p> <p>100 V and 4 Ohm outputs.</p> <p>Mounting on vehicles and tabletop.</p>
POWER	15 W RMS
RESPONSE	20-20,000 Hz ± 3 dB
DISTORTION	Harmonic: <1% at 1 kHz
INPUTS	<p>1 balanced / unbalanced mic, euroblock / 6.3 mm jack, 600 Ohm 6 mV RMS</p> <p>1 auxiliary, euroblock / 2 x RCA, 47,000 Ohm 300 mV RMS</p> <p>1 line 100 V, euroblock</p>
FUNCTIONS	<p>Input priority.</p> <p>100V Emergency input with maximum priority, attenuates all other inputs.</p> <p>Mute by contact closure, attenuates all inputs except the 100V Emergency input.</p> <p>Microphone with priority over Aux and Player inputs, by signal level, selectable.</p> <p>Power on, protection, signal peak and output signal indicator lights</p> <p>Fanless induction cooling</p>

CONTROLS	Microphone volume Selected input volume Input selector USB/FM player controls Tone: bass and treble Microphone gain and priority
PLAYER	USB player with background music playback mode. When switched on, automatically starts playback FM digital tuner with presets and auto-scan Memory of last selected mode (USB or FM), last played song or last tuned station. Starts playback in successive order
IMPEDANCE	4 Ohm and 100 V line, euroblock
POWER SUPPLY	230/115 V AC, 50 W and 12 V DC, 15 W
DIMENSIONS	254 x 84 x 225 mm depth
WEIGHT	3.5 kg
ACCESSORIES	FM antenna
OPTIONAL	PROX-15SP: surface mount bracket

Frequency reponse

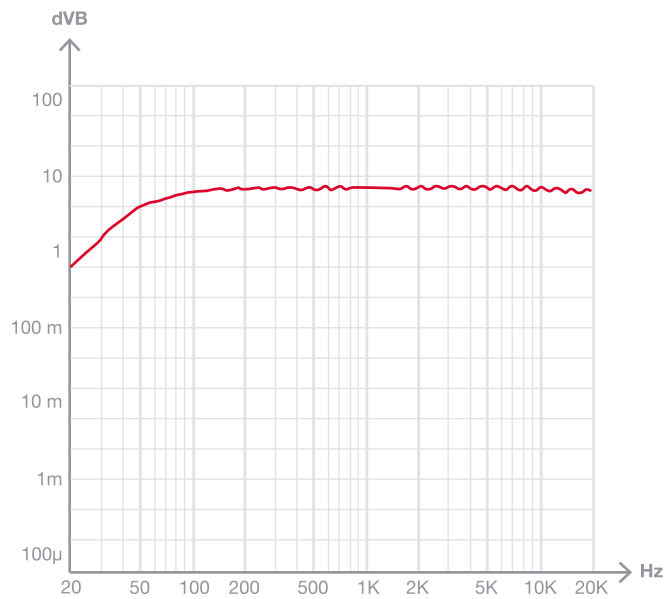

Block diagram

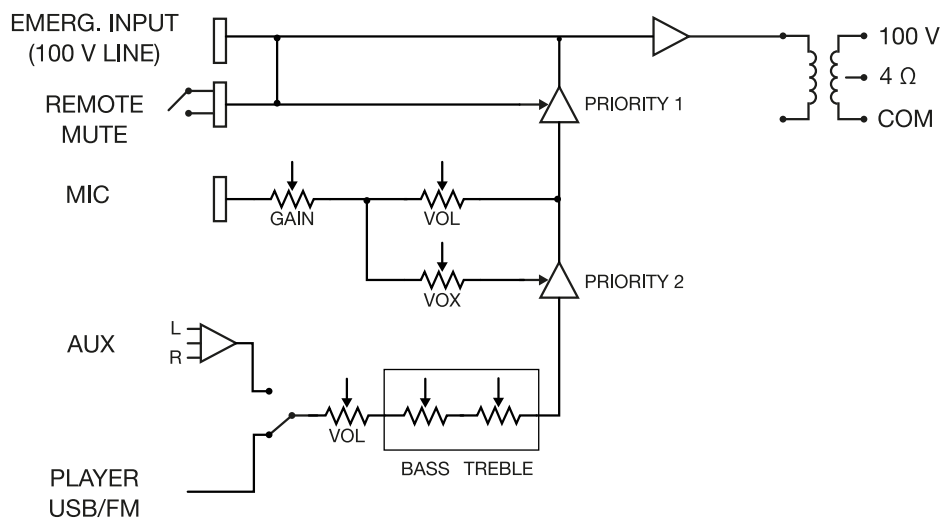

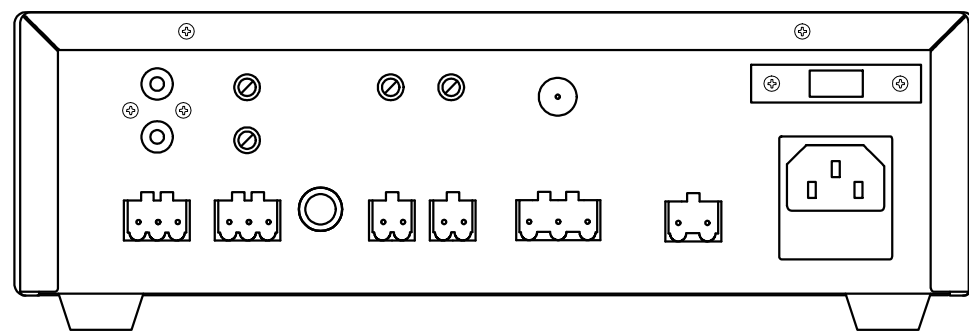
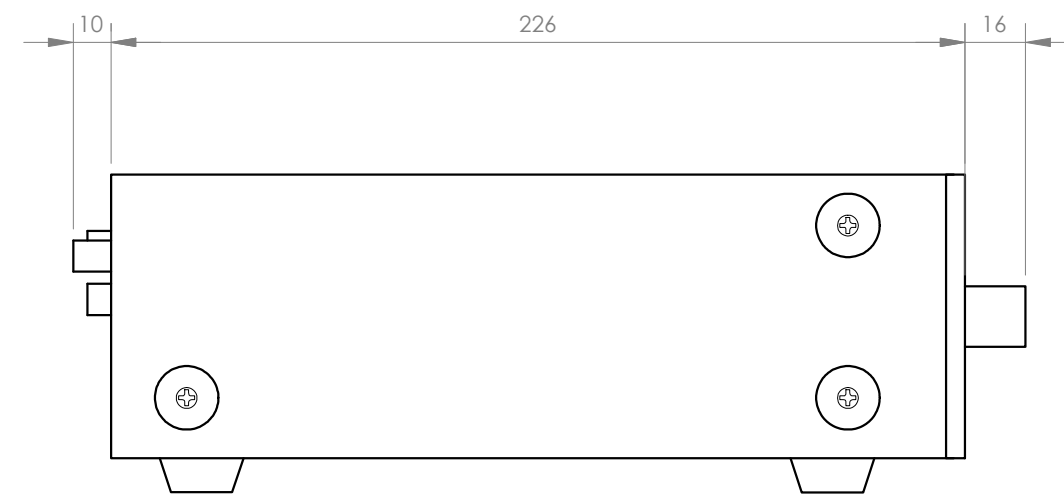
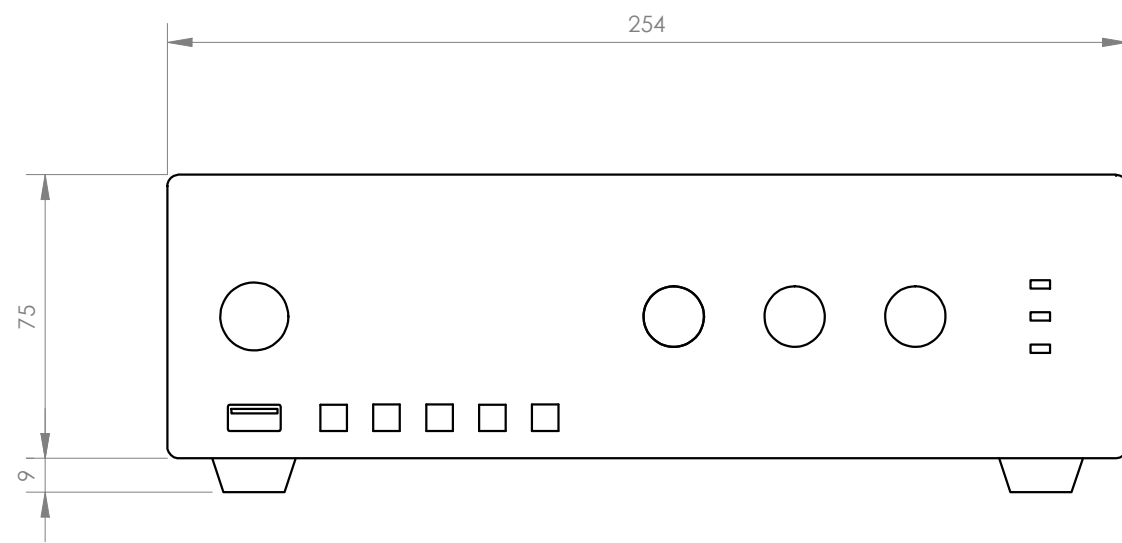

FONESTAR	Model	Description	Units	Scale
	PROX-15	PA SINGLE ZONE AMPLIFIER	mm	1:2