

PUBLIC ADDRESS / AMPLIFIERS / MONO

## PROX-120S

PA SINGLE ZONE AMPLIFIER

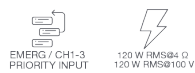

- ✓ PA versatile amplifier
- ✓ Microphone inputs with mix, gain and priority level control
- ✓ Great performance, low maintenance

ESPECIALLY RECOMMENDED IN:



Factories



Sports facilities



Education



All sectors

## DESCRIPTION

PA amplifier The best tool for venue sound installation. Reliable for long working days. Distributed audio for PA installations with 100 V loudspeakers, also with low impedance output. User-friendly operation and a modern, discreet design. A solution to suit any budget. Safe and durable connections with low maintenance. Perfect for public address and piped music systems with 100 V or low impedance line speakers. Retail, educational centres, monuments, exhibitions, bars, restaurants, etc.

## TECHNICAL CHARACTERISTICS

FEATURES	<p>PA Amplifier</p> <p>Microphone inputs with mix, gain and priority level control.</p> <p>Input priorities by signal level.</p> <p>Tone controls.</p> <p>100 V and 4 Ohm outputs.</p>
POWER	120 W RMS
RESPONSE	40–20,000 Hz (–10 dB)
DISTORTION	THD+N: < 1% @ 1 kHz
S/N RATIO	>77 dB
PROTECTIONS	Overcurrent, DC and short-circuit at the output
INPUTS	<p>CH 1 balanced mic/line with 48V Phantom, Combo connector (XLR + 6.3mm) and euroblock</p> <p>CH 2 and 3 mic/line balanced with 48V Phantom. Euroblock connector</p> <p>Mic signal level: 6 mV RMS (–44 dBV) / 600 Ohm</p> <p>Line signal level: 250 mV RMS (–12 dBV) / 100k Ohm</p> <p>2 AUX. 2 x RCA and euroblock connector. Signal level 300 mV RMS (–10 dBV) / 47,000 Ohm</p> <p>1 emergency. Euroblock connector. Signal level loudspeaker line 100 V</p> <p>1 Mute (Emergency Priority) by contact closure. Euroblock connector</p>
OUTPUTS	<p>1 line. 2 x RCA connector. 1.25 V RMS (+2 dBV) signal level</p> <p>100 V or 4 Ohm speaker output. Connector screw terminals</p>
IMPEDANCE	4 Ohm and 100 V line (83 Ohm)

FUNCTIONS	<p>Input priority (Voice over VOX inputs):            100V Emergency input with highest priority, attenuates all other inputs.            Mute by contact closure, attenuates all inputs except the 100V Emergency input.            Channel 1 with priority over all other inputs, level selectable.            Channel 2 and 3 with priority over auxiliary inputs, level selectable.            Other functions:            Power on, protection, signal peak and output signal indicators.            Temperature-controlled cooling by forced ventilation</p>
CONTROLS	<p>Microphone volume            Mic/line/phantom selector            Master volume            Aux input selector            Tone: bass and treble (+/- 10 dB 100 Hz and 10k Hz)            Microphone gain            Priority activation signal level (VOX)</p>
OPERATING TEMPERATURE	<p>Operation: 0° ~ 40°C</p>
MAXIMUM HUMIDITY	<p>95%</p>
POWER SUPPLY	<p>230/115 V AC 50-60 Hz, 320 W            Fuse AC 230 V 3.15 A / 115 V 6 A</p>
DIMENSIONS	<p>433 x 89 x 360 mm depth. 2 U 19" rack</p>
WEIGHT	<p>9.5 kg</p>
ACCESSORIES	<p>Power cable            Rack mounts</p>

## Frequency response

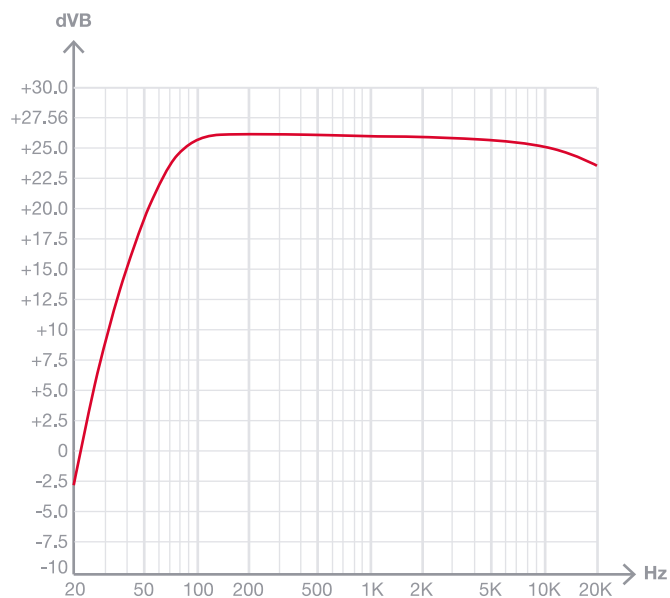

## Block diagram

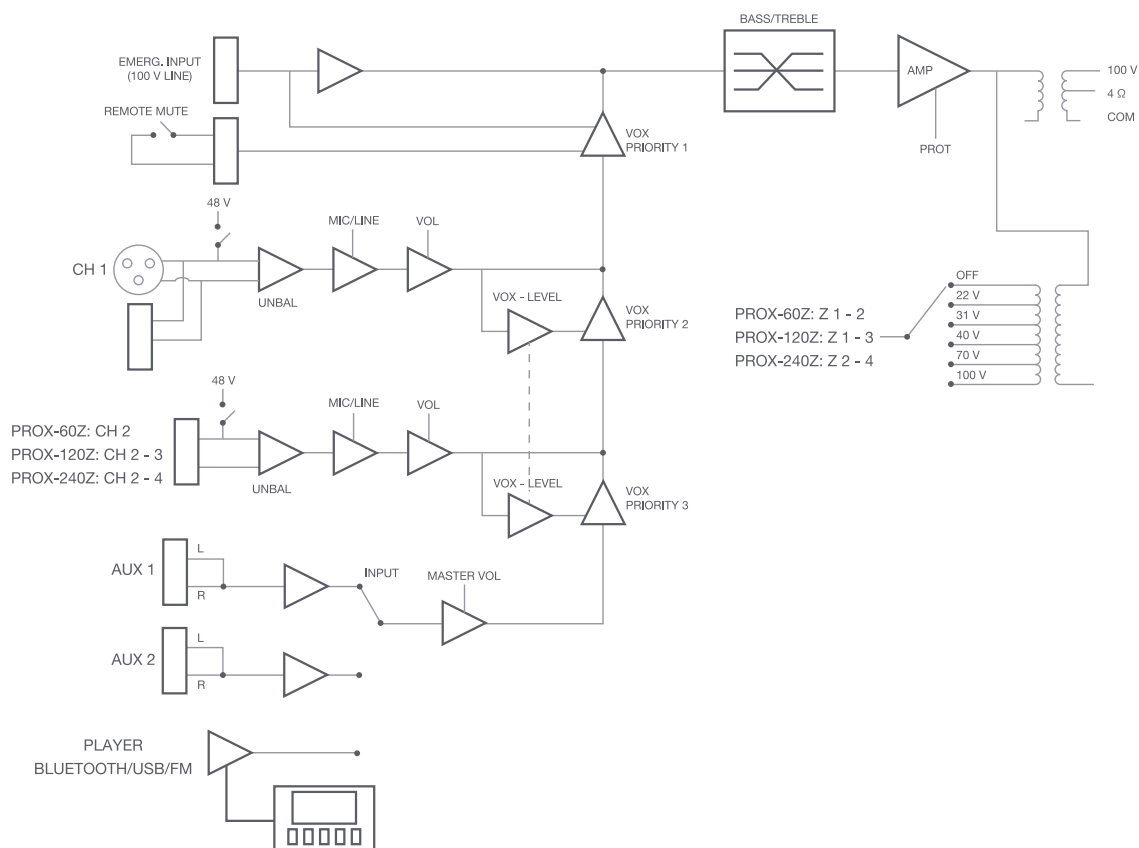

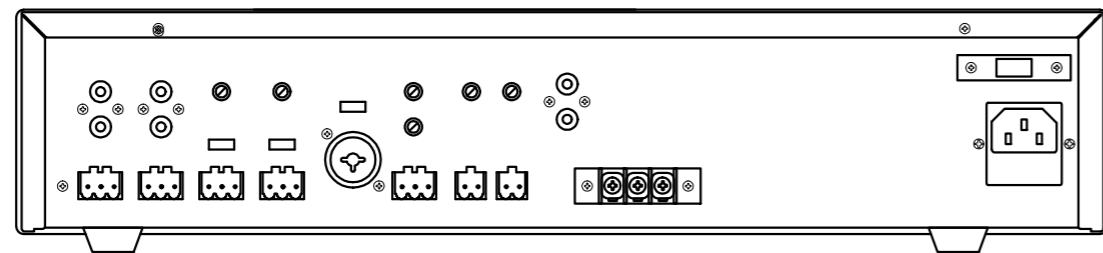
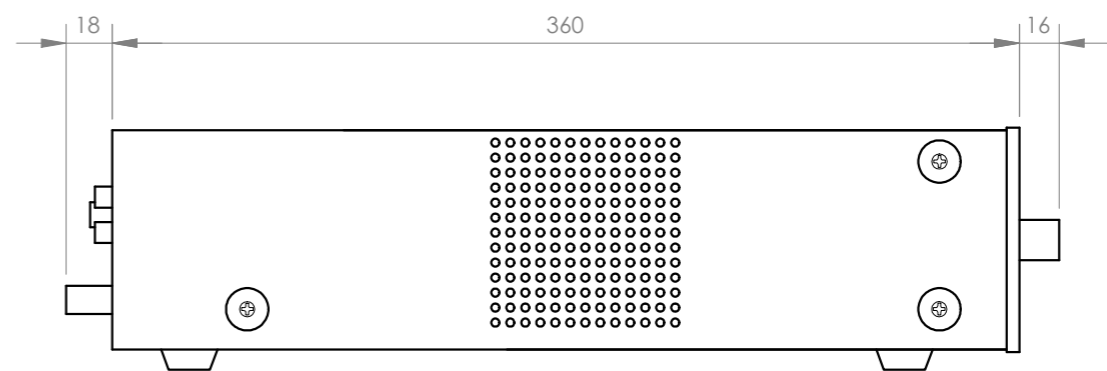
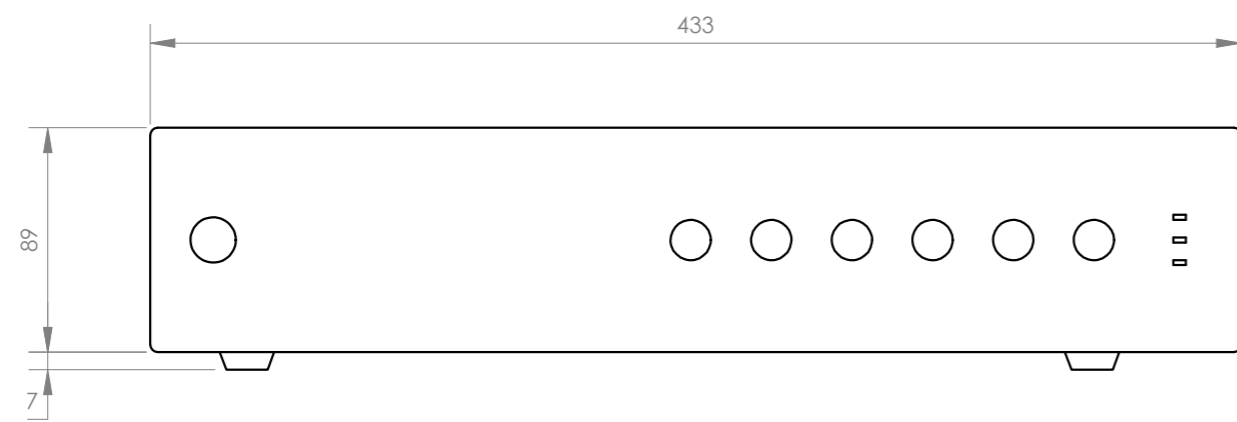

<b>FONESTAR</b>	Model	Description	Units	Scale
	PROX-120S	PA SINGLE AMPLIFIER	mm	1:3