

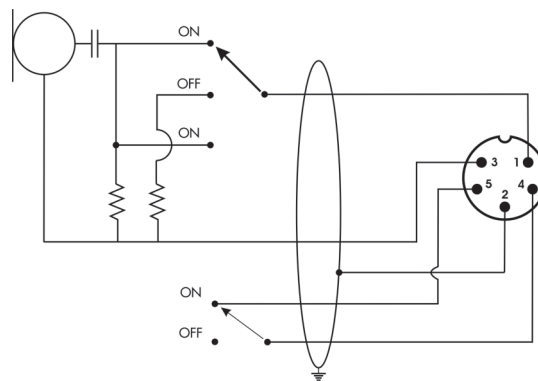

FDM-629-DIN5

DYNAMIC DESKTOP MICROPHONE

FONESTAR



SPECIFICATIONS

	FDM-629-DIN5
CHARACTERISTICS	Desktop microphone. Stylish design.
CAPSULE	Unidirectional dynamic
RESPONSE	100-18,000 Hz
SENSITIVITY	-64 dB ±3 dB (V/Pa) at 1 kHz
IMPEDANCE	600 Ω
BUTTON	3 positions: press on, fixed on and off Double circuit
HEIGHT	Total: 36 cm with tube and gooseneck and desktop base
CABLE	1.7 m with DIN 5 connector for contact closure using button Unbalanced line
COMPATIBILITY	For musical chimes and priority in FONESTAR amplifiers models FS-2002M, FS-2005-SR, FS-2061 and FS-2121

DECLARATION OF CONFORMITY



FONESTAR SISTEMAS S.A.

Polígono de Trascueto s/n
39600 Revilla de Camargo, Cantabria (Spain)

Declares, under its responsibility, that the following equipment:

Description: Dynamic desktop microphone
Brand: FONESTAR
Model: FDM-629-DIN5

complies with the European Community directives 2004/108/CE on Electromagnetic Compatibility and 2011/65/UE on the restriction of certain dangerous substances in electrical and electronic appliances (RoHS).

Revilla de Camargo, 8th September 2.015

Juan Vallejo
Technical Engineer, Sales Department

WARRANTY

This product has been tested and has passed the corresponding quality control prior to being put on the market.

FONESTAR guarantees the suitability of the product for its specified use during a period of 2 years from the delivery date and commits itself to repair or substitute the goods as expressed in the Spanish law 'La Ley General para la Defensa de los Consumidores y Usuarios, Real Decreto Legislativo 1/2007 16 Noviembre.

The lack of conformity in the first six months after purchase, due to a manufacturing defect, will be rectified with no more than showing the proof of purchase. After six months **FONESTAR** reserves the right to demand proof of the product being sold with that problem.

This warranty does not include damage produced by: inappropriate use or negligence, accidents, worn out parts due to use, breakages, burns, spilt liquids or other substances, excessive humidity, battery deterioration and internal manipulation of the device, the software or its components by unauthorized persons, and in general any use that is unrelated to the nature and purpose of the product.

If any service is needed during the warranty period because of lack of conformity, please contact the business or distributor where the product was purchased in no more than 2 months after being conscious of the problem. It is only necessary to contact **FONESTAR** if it is impossible or imposes an undue burden for them to solve it.

To benefit from this warranty it is necessary to show the proof of purchase with the date clearly visible, with no corrections or crossing out.

This document adds information, and never decreases the consumers' rights, which in all cases are protected by the Spanish law 'La Ley General para la Defensa de los Consumidores y Usuarios, Real Decreto Legislativo 1/2007 16 Noviembre.



FONESTAR is a member of ECOEMBALAJES ESPAÑA, S.A. "ECOEMBES", with number 03497 and all our products carry the symbol, backed by our membership and subscription to the above mentioned organization with the recycling and subsequent management of our packaging.

FONESTAR is registered in the RAEE (Registro de Aparatos Eléctricos y Electrónicos) in a special section REI (Registro de establecimientos Industriales), with the entry number 001851.

FONESTAR S.A. - NIF A28780443 - Apartado 191 - 39080 - Santander, Cantabria (Spain)