

DESCRIPTION

Hanging cardioid electret condenser microphone, suitable for hanging over choirs, in theatres, orchestras and wherever it may be needed.

INSTALLATION

Follow the steps below to hang the microphone from the ceiling using the hanging support included:

1.- Fit the microphone in the hanging support by passing the cable through the spiral as shown in the figures below:

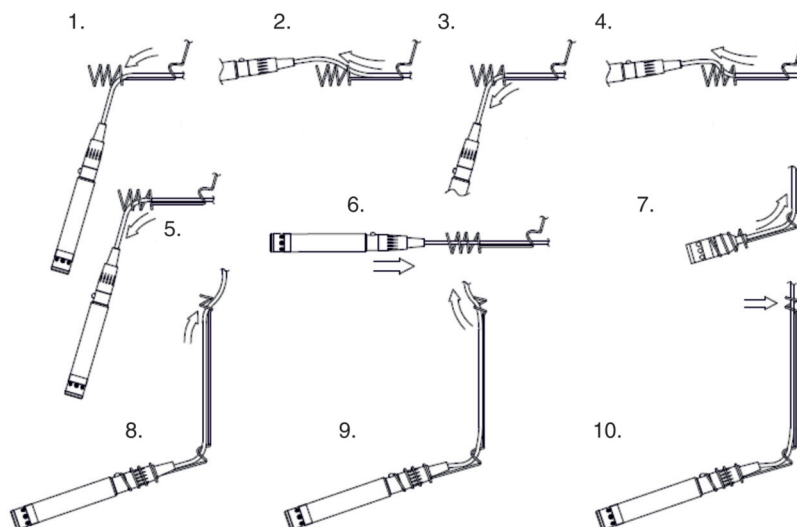

2.- Hang the microphone from the ceiling or any other appropriate position.

3.- You can move the microphone in any direction by simply turning it gently together with the hanging support.

4.- Adjust the height the microphone hangs at according to your needs.

TECHNICAL SPECIFICATIONS

	FCM-804
CHARACTERISTICS	Hanging microphone for stages, choirs, etc. Atmospheric sound pick-up. Minimum visual effect. Stainless steel hanger. Anti-reflecting black finish.
CAPSULE	Unidirectional cardioid electret condenser
RESPONSE	50-18,000 Hz
SENSITIVITY	-38 dB ±3 dB (V/Pa) at 1 kHz
IMPEDANCE	250 Ω ±30% at 1 kHz
PHANTOM	9 to 52 V DC
CABLE	9.5 m with mini female XLR connectors to male XLR
DIMENSIONS	12 mm Ø x 65 mm length
ACCESSORIES	Protective case, hanging support and windshield

WARRANTY

This product has been tested and has passed the corresponding quality control prior to being put on the market.

FONESTAR guarantees the suitability of the product for its specified use during a period of 2 years from the delivery date and commits itself to repair or substitute the goods as expressed in the Spanish law 'La Ley General para la Defensa de los Consumidores y Usuarios, Real Decreto Legislativo 1/2007 16 Noviembre.

The lack of conformity in the first six months after purchase, due to a manufacturing defect, will be rectified with no more than showing the proof of purchase. After six months **FONESTAR** reserves the right to demand proof of the product being sold with that problem.

This warranty does not include damage produced by: inappropriate use or negligence, accidents, worn out parts due to use, breakages, burns, spilt liquids or other substances, excessive humidity, battery deterioration and internal manipulation of the device, the software or its components by unauthorized persons, and in general any use that is unrelated to the nature and purpose of the product.

If any service is needed during the warranty period because of lack of conformity, please contact the business or distributor where the product was purchased in no more than 2 months after being conscious of the problem. It is only necessary to contact **FONESTAR** if it is impossible or imposes an undue burden for them to solve it.

To benefit from this warranty it is necessary to show the proof of purchase with the date clearly visible, with no corrections or crossing out.

This document adds information, and never decreases the consumers' rights, which in all cases are protected by the Spanish law 'La Ley General para la Defensa de los Consumidores y Usuarios, Real Decreto Legislativo 1/2007 16 Noviembre.



FONESTAR is a member of ECOEMBALAJES ESPAÑA, S.A. "ECOEMBES", with number 03497 and all our products carry the symbol, backed by our membership and subscription to the above mentioned organization with the recycling and subsequent management of our packaging.

FONESTAR is registered in the RAEE (Registro de Aparatos Eléctricos y Electrónicos) in a special section REI (Registro de establecimientos Industriales), with the entry number 001851.

FONESTAR S.A. - NIF A28780443 - Poligono Trascueto - 39600 Revilla de Camargo, Cantabria (Spain)